

CATÁLOGO DE PERFILES DE GOMA ESPONJA

SPONGE RUBBER PROFILES CATALOG

- PLETINAS
- CORDONES
- TUBOS
- FORMA DE "U"

PLETINAS DE ESPONJA/SPONGE RUBBER STRIPS _____ 3

LONGITUD MÁXIMA ENTRE 0,1MM Y 10 MM _____	3
LONGITUD MÁXIMA ENTRE 10.01MM Y 20 MM _____	4
LONGITUD MÁXIMA ENTRE 20.01MM Y 30 MM _____	6
LONGITUD MÁXIMA ENTRE 30.01MM Y 40 MM _____	7
LONGITUD MÁXIMA ENTRE 40.01MM Y 50 MM _____	8
LONGITUD MÁXIMA SUPERIOR A 50,1 MM _____	8

CORDONES DE ESPONJA/SPONGE RUBBER CORDS _____ 9

DIÁMETRO ENTRE 0.1MM Y 10MM _____	9
DIÁMETRO ENTRE 10.1MM Y 20MM _____	10
DIÁMETRO SUPERIOR A 20.1MM _____	10

TUBOS DE ESPONJA/SPONGE RUBBER TUBES _____ 11

PERFILES CON FORMA DE “U”/ SPONGE RUBBER “U” PROFILES _____ 12

PERFILES SIMÉTRICOS _____	12
PERFILES ASIMÉTRICOS _____	15

PLETINAS DE ESPONJA / SPONGE STRIPS

LONGITUD MÁXIMA ENTRE 0,1MM Y 10 MM

Ancho (mm)	Alto(mm)	Referencia	Detalles
4	3	E-473/A0	EPDM DENSIDAD: 0.40 GR/CM ³
4	3.25	E-479/A0	EPDM DENSIDAD: 0.30 GR/CM ³
4	4	E-387/A0	EPDM DENSIDAD: 0.30 GR/CM ³
5.8	4	E-386/A0	EPDM DENSIDAD: 0.70 GR/CM ³
6.6	4.5	E-517/A0	EPDM DENSIDAD: 0.40 GR/CM ³
5	2	E-34/A0	EPDM DENSIDAD: 0.40 GR/CM ³
5	3.5	E-303/A0	EPDM DENSIDAD: 0.40 GR/CM ³
5.6	5	E-399/A0	EPDM DENSIDAD: 0.30 GR/CM ³
6	3.1	E-681/A	EPDM DENSIDAD: 0.65 GR/CM ³
6	4	E-242/A0	EPDM DENSIDAD: 0.30 GR/CM ³
		E-242/B0	EPDM DENSIDAD: 0.60 GR/CM ³
6	4.5	E-238/A0	EPDM DENSIDAD: 0.60 GR/CM ³
		E-238/B0	EPDM DENSIDAD: 0.50 GR/CM ³
		E-238/C0	EPDM DENSIDAD: 0.40 GR/CM ³
		E-238/D0	EPDM DENSIDAD: 0.30 GR/CM ³
6	5.5	E-528/A0	EPDM DENSIDAD: 0.60 GR/CM ³
6	6	E-181/A0	EPDM DENSIDAD: 0.30 GR/CM ³
6	6	E-697/A0	EPDM DENSIDAD: 0.40 GR/CM ³
6.35	3.5	E-90/A0	EPDM DENSIDAD: 0.45 GR/CM ³
6.5	5	E-614/A0	EPDM DENSIDAD: 0.40 GR/CM ³
6.5	5	E-530/A0	EPDM DENSIDAD: 0.60 GR/CM ³
6.5	6.5	E-400/A0	EPDM DENSIDAD: 0.40 GR/CM ³
		E-400/F0	EPDM DENSIDAD: 0.65 GR/CM ³
7	5	E-523/A0	EPDM DENSIDAD: 0.40 GR/CM ³
		E-523/B0	EPDM DENSIDAD: 0.60 GR/CM ³

Ancho (mm)	Alto(mm)	Referencia	Detalles
7	5	E-698/A0	EPDM DENSIDAD: 0.80 GR/CM ³
7.5	3	E-251/A0	EPDM DENSIDAD: 0.40 GR/CM ³
7.5	3.8	E-330/A0	EPDM DENSIDAD: 0.30 GR/CM ³
7.5	5	E-264/A0	A CONSULTAR
7.5	5.4	E-275/A0	EPDM DENSIDAD: 0.40 GR/CM ³
8	2	E-305/A0	EPDM DENSIDAD: 0.30 GR/CM ³
8	4.5	E-306/A0	EPDM DENSIDAD: 0.30 GR/CM ³
8	5	E-23/A0	EPDM DENSIDAD: 0.40 GR/CM ³
8	5	E-680/A0	EPDM DENSIDAD: 0.55 GR/CM ³
8	6	E-49/A0	EPDM DENSIDAD: 0.40 GR/CM ³
8	6.5	E-348/A0	EPDM DENSIDAD: 0.40 GR/CM ³
8	6.5	E-293/B0	EPDM DENSIDAD: 0.60 GR/CM ³
8	8	E-60/A0	EPDM DENSIDAD: 0.40 GR/CM ³
9	4	E-304/A0	EPDM DENSIDAD: 0.30 GR/CM ³
10	3	E-113/A0	EPDM DENSIDAD: 0.40 GR/CM ³
10	4	E-40/A0	EPDM DENSIDAD: 0.30 GR/CM ³
		E-40-A/A0	EPDM DENSIDAD: 0.40 GR/CM ³
10	5	E-43/A0	EPDM DENSIDAD: 0.40 GR/CM ³
10	7	E-187/A0	EPDM DENSIDAD: 0.40 GR/CM ³
10	10	E-325/A0	EPDM DENSIDAD: 0.40 GR/CM ³

LONGITUD MÁXIMA ENTRE 10.01MM Y 20 MM

Ancho (mm)	Alto(mm)	Referencia	Detalles
11.6	4.5	E-581/A0	EPDM DENSIDAD: 0.60 GR/CM ³
12	3	E-215/A0	EPDM DENSIDAD: 0.40 GR/CM ³
12	4	E-422/A0	EPDM DENSIDAD: 0.40 GR/CM ³
12	5	E-650/A0	EPDM DENSIDAD: 0.60 GR/CM ³
12	6	E-103/A0	EPDM DENSIDAD: 0.40 GR/CM ³
12	8	E-61/A0	EPDM DENSIDAD: 0.40 GR/CM ³
12	9	E-64/A0	EPDM DENSIDAD: 0.40 GR/CM ³

Ancho (mm)	Alto(mm)	Referencia	Detalles
12	12	E-174/A0	EPDM DENSIDAD: 0.40 GR/CM ³
14	4	E-392/A0	EPDM DENSIDAD: 0.60 GR/CM ³
14	4.8	E-393/A0	EPDM DENSIDAD: 0.60 GR/CM ³
14	7.5	E-394/A0	EPDM DENSIDAD: 0.60 GR/CM ³
14	8.5	E-676/A0	EPDM DENSIDAD: 0.55 GR/CM ³
14	9.7	E-501/A0	EPDM DENSIDAD: 0.50 GR/CM ³
14	10	E-492/A0	EPDM DENSIDAD: 0.40 GR/CM ³
14	14	E-268/A0	EPDM DENSIDAD: 0.50 GR/CM ³
15	2	E-35/A0	EPDM DENSIDAD: 0.40 GR/CM ³
15	3	E-203/A0	EPDM DENSIDAD: 0.40 GR/CM ³
15	3.8	E-42/A0	EPDM DENSIDAD: 0.40 GR/CM ³
15	5	E-115/A0	EPDM DENSIDAD: 0.40 GR/CM ³
15	5	E-672/A0	EPDM DENSIDAD: 0.85 GR/CM ³
15	6	E-50/A0	EPDM DENSIDAD: 0.30 GR/CM ³
15	7	E-53/A0	EPDM DENSIDAD: 0.40 GR/CM ³
15	10	E-126/A0	EPDM DENSIDAD: 0.40 GR/CM ³
		E-126/B0	EPDM DENSIDAD: 0.30 GR/CM ³
15	12	E-175/A0	EPDM DENSIDAD: 0.40 GR/CM ³
15	15	E-76/A0	EPDM DENSIDAD: 0.40 GR/CM ³
16	5	E-44/A0	EPDM DENSIDAD: 0.40 GR/CM ³
17	8	E-89/A0	EPDM DENSIDAD: 0.40 GR/CM ³
18	3	E-38/A0	EPDM DENSIDAD: 0.40 GR/CM ³
18	5.3	E-100/A0	EPDM DENSIDAD: 0.40 GR/CM ³
18	6.3	E-382/A0	EPDM DENSIDAD: 0.60 GR/CM ³
18	9	E-65/A0	EPDM DENSIDAD: 0.40 GR/CM ³
19	4	E-32/A0	EPDM DENSIDAD: 0.40 GR/CM ³
20	2	E-33/A0	EPDM DENSIDAD: 0.40 GR/CM ³
20	3	E-153/A0	EPDM DENSIDAD: 0.40 GR/CM ³
20	5	E-45/A0	EPDM DENSIDAD: 0.40 GR/CM ³
20	5.5	E-88/A0	EPDM DENSIDAD: 0.45 GR/CM ³
20	7.5	E-395/A0	EPDM DENSIDAD: 0.60 GR/CM ³

Ancho (mm)	Alto(mm)	Referencia	Detalles
20	10	E-67/A0	EPDM DENSIDAD: 0.40 GR/CM ³
		E-67/B0	EPDM DENSIDAD: 0.30 GR/CM ³
20	12	E-73/A0	EPDM DENSIDAD: 0.40 GR/CM ³
20	15	E-77/A0	EPDM DENSIDAD: 0.40 GR/CM ³
		E-77/B0	EPDM DENSIDAD: 0.30 GR/CM ³
20	18	E-80/A0	EPDM DENSIDAD: 0.40 GR/CM ³
20	20	E-81/A0	EPDM DENSIDAD: 0.40 GR/CM ³

LONGITUD MÁXIMA ENTRE 20.01MM Y 30 MM

Ancho (mm)	Alto(mm)	Referencia	Detalles
22	7	E-54/A0	EPDM DENSIDAD: 0.40 GR/CM ³
25	2	E-36/A0	EPDM DENSIDAD: 0.40 GR/CM ³
		E-36/C0	EPDM DENSIDAD: 0.65 GR/CM ³
		E-36/D0	EPDM DENSIDAD: 0.50 GR/CM ³
25	3	E-619/A0	EPDM DENSIDAD: 0.40 GR/CM ³
25	5	E-211/A0	EPDM DENSIDAD: 0.40 GR/CM ³
25	6	E-51/A0	EPDM DENSIDAD: 0.40 GR/CM ³
		E-51/B0	EPDM DENSIDAD: 0.65 GR/CM ³
25	8	E-63/A0	EPDM DENSIDAD: 0.40 GR/CM ³
25	10	E-68/A0	EPDM DENSIDAD: 0.40 GR/CM ³
		E-68/B0	EPDM DENSIDAD: 0.80 GR/CM ³
25	15	E-78/A0	EPDM DENSIDAD: 0.40 GR/CM ³
25	20	E-151/A0	EPDM DENSIDAD: 0.40 GR/CM ³
25	25	E-84/A0	EPDM DENSIDAD: 0.40 GR/CM ³
26.3	5	E-542/A0	EPDM DENSIDAD: 0.60 GR/CM ³
28	5.5	E-91/A0	EPDM DENSIDAD: 0.40 GR/CM ³
30	5	E-624/A0	EPDM DENSIDAD: 0.40 GR/CM ³
30	7	E-59/A0	EPDM DENSIDAD: 0.40 GR/CM ³
30	7.5	E-565/A0	EPDM DENSIDAD: 0.40 GR/CM ³

Ancho (mm)	Alto(mm)	Referencia	Detalles
30	10	E-69/A0	EPDM DENSIDAD: 0.40 GR/CM ³
30	12	E-74/A0	EPDM DENSIDAD: 0.40 GR/CM ³
30	15	E-127/A0	EPDM DENSIDAD: 0.40 GR/CM ³
30	20	E-82/A0	EPDM DENSIDAD: 0.40 GR/CM ³
30	25	E-204/A0	EPDM DENSIDAD: 0.40 GR/CM ³
30	30	E-85/A0	EPDM DENSIDAD: 0.40 GR/CM ³

LONGITUD MÁXIMA ENTRE 30.01MM Y 40 MM

Ancho (mm)	Alto(mm)	Referencia	Detalles
31	3	E-146/A0	EPDM DENSIDAD: 0.40 GR/CM ³
35	2	E-37/A0	EPDM DENSIDAD: 0.40 GR/CM ³
35	5	E-214/A0	EPDM DENSIDAD: 0.40 GR/CM ³
35	15	E-500/A0	EPDM DENSIDAD: 0.60 GR/CM ³
35	35	E-176/A0	EPDM DENSIDAD: 0.40 GR/CM ³
40	3.5	E-39/A0	EPDM DENSIDAD: 0.40 GR/CM ³
40	5	E-47/A0	EPDM DENSIDAD: 0.40 GR/CM ³
40	10	E-70/A0	EPDM DENSIDAD: 0.40 GR/CM ³
		E-70/B0	EPDM DENSIDAD: 0.30 GR/CM ³
40	12	E-75/A0	EPDM DENSIDAD: 0.40 GR/CM ³
40	15	E-599/A0	EPDM DENSIDAD: 0.40 GR/CM ³
40	20	E-83/A0	EPDM DENSIDAD: 0.40 GR/CM ³
40	20	E-675/A0	EPDM DENSIDAD: 0.70 GR/CM ³
		E-675/B0	EPDM DENSIDAD: 0.80 GR/CM ³
40	30	E-124/A0	EPDM DENSIDAD: 0.40 GR/CM ³
40	35	E-143/A0	EPDM DENSIDAD: 0.40 GR/CM ³
40	40	E-144/A0	EPDM DENSIDAD: 0.40 GR/CM ³

LONGITUD MÁXIMA ENTRE 40.01MM Y 50 MM

Ancho (mm)	Alto(mm)	Referencia	Detalles
45	5	E-48/A0	EPDM DENSIDAD: 0.40 GR/CM ³
50	5	E-212/A0	EPDM DENSIDAD: 0.40 GR/CM ³
50	6	E-52/A0	EPDM DENSIDAD: 0.40 GR/CM ³
50	10	E-71/A0	EPDM DENSIDAD: 0.40 GR/CM ³
		E-71/D0	EPDM DENSIDAD: 0.60 GR/CM ³
50	20	E-439/A0	EPDM DENSIDAD: 0.40 GR/CM ³
50	30	E-183/A0	EPDM DENSIDAD: 0.40 GR/CM ³
50	50	E-634/A0	EPDM DENSIDAD: 0.40 GR/CM ³
		E-634/D0	EPDM DENSIDAD: 0.50 GR/CM ³

LONGITUD MÁXIMA SUPERIOR A 50,1 MM

Ancho (mm)	Alto(mm)	Referencia	Detalles
53	13	E-457/A0	EPDM DENSIDAD: 0.40 GR/CM ³
55	15	E-79/A0	EPDM DENSIDAD: 0.40 GR/CM ³
60	10	E-72/A0	EPDM DENSIDAD: 0.40 GR/CM ³
60	20	E-637/A0	EPDM DENSIDAD: 0.40 GR/CM ³
60	40	E-184/A0	EPDM DENSIDAD: 0.65 GR/CM ³
		E-184/B0	EPDM DENSIDAD: 0.40 GR/CM ³
62	22	E-221/A0	EPDM DENSIDAD: 0.40 GR/CM ³
70	10	E-274/A0	EPDM DENSIDAD: 0.40 GR/CM ³
72.5	65	E-141/A0	A CONSULTAR
80	35	E-269/A0	EPDM DENSIDAD: 0.40 GR/CM ³
90	76	E-138//A0	A CONSULTAR
93	85	E-139//A0	A CONSULTAR
100	60	E-142/A0	A CONSULTAR
125	10	E-218/A0	A CONSULTAR

CORDONES DE ESPONJA / SPONGE CORDS

DIÁMETRO ENTRE 0.1MM Y 10MM

Diámetro Ø (mm)	Referencia	Detalles
3	E-229/A0	EPDM DENSIDAD: 0.40 GR/CM ³
3.25	E-455/A0	EPDM DENSIDAD: 0.40 GR/CM ³
4	E-279/A0	EPDM DENSIDAD: 0.40 GR/CM ³
4	E-646/A0	A CONSULTAR
4.2	E-658/A0	EPDM DENSIDAD: 0.55 GR/CM ³
4.5	E-349/A0	EPDM DENSIDAD: 0.30 GR/CM ³
4.5	E-86/A0	EPDM DENSIDAD: 0.40 GR/CM ³
4.6	E-321/A0	EPDM DENSIDAD: 0.70 GR/CM ³
5	E-589/A0	EPDM DENSIDAD: 0.40 GR/CM ³
5.5	E-506/A0	EPDM DENSIDAD: 0.40 GR/CM ³
	E-506/C0	EPDM DENSIDAD: 0.30 GR/CM ³
6	E-87/A0	EPDM DENSIDAD: 0.40 GR/CM ³
	E-87/B0	EPDM DENSIDAD: 0.60 GR/CM ³
	E-87/C0	CR DENSIDAD: 0.65 GR/CM ³
	E-87/J0	EPDM DENSIDAD: 0.50 GR/CM ³
6	E-654/A0	EPDM DENSIDAD: 0.55 GR/CM ³
6.7	E-447/A0	EPDM DENSIDAD: 0.30 GR/CM ³
7	E-158/A0	EPDM DENSIDAD: 0.40 GR/CM ³
	E-158/C0	EPDM DENSIDAD: 0.60 GR/CM ³
7.7	E-647/A0	EPDM DENSIDAD: 0.55 GR/CM ³
8	E-56/C0	EPDM DENSIDAD: 0.40 GR/CM ³
9	E-55/A0	EPDM DENSIDAD: 0.40 GR/CM ³
	E-55/B0	EPDM DENSIDAD: 0.30 GR/CM ³
	E-55/C0	EPDM DENSIDAD: 0.60 GR/CM ³
10	E-57/A0	EPDM DENSIDAD: 0.40 GR/CM ³

DIÁMETRO ENTRE 10.1MM Y 20MM

Diámetro Ø (mm)	Referencia	Detalles
11	E-159/A0	EPDM DENSIDAD: 0.40 GR/CM ³
11	E-694/A0	EPDM DENSIDAD: 0.55 GR/CM ³
12	E-58/A0	EPDM DENSIDAD: 0.30 GR/CM ³
	E-58/B0	EPDM DENSIDAD: 0.60 GR/CM ³
	E-58/C0	EPDM DENSIDAD: 0.40 GR/CM ³
13	E-160/A0	EPDM DENSIDAD: 0.40 GR/CM ³
14	E-161/A0	EPDM DENSIDAD: 0.40 GR/CM ³
15	E-162/A0	EPDM DENSIDAD: 0.40 GR/CM ³
16	E-163/A0	EPDM DENSIDAD: 0.40 GR/CM ³
17	E-164/A0	EPDM DENSIDAD: 0.40 GR/CM ³
18	E-165/A0	A CONSULTAR
19	E-166/A0	A CONSULTAR
20	E-167/A0	EPDM DENSIDAD: 0.40 GR/CM ³

DIÁMETRO SUPERIOR A 20.1MM

Diámetro Ø (mm)	Referencia	Detalles
22.5	E-554/A0	EPDM DENSIDAD: 0.40 GR/CM ³
23.5	E-311/A0	EPDM DENSIDAD: 0.40 GR/CM ³
50	E-380/A0	EPDM DENSIDAD: 0.40 GR/CM ³

TUBOS DE ESPONJA / SPONGE TUBES

Ø Externo (mm)	Ø Interno (mm)	Referencia	Detalles
8	4	E-585/A0	EPDM DENSIDAD: 0.60 GR/CM ³
12.5	8.5	E-276/A0	EPDM DENSIDAD: 0.60 GR/CM ³
15	9.5	E-553/A0	EPDM DENSIDAD: 0.40 GR/CM ³
18	7.7	E-259/A0	A CONSULTAR
18	10	E-346/A0	EPDM DENSIDAD: 0.60 GR/CM ³
20	8	E-376/A0	EPDM DENSIDAD: 0.50 GR/CM ³
20	12	E-185/A0	EPDM DENSIDAD: 0.60 GR/CM ³
24	5	E-178/A0	EPDM DENSIDAD: 0.40 GR/CM ³
24	16	E-448/A0	EPDM DENSIDAD: 0.50 GR/CM ³
26	16	E-231/A0	EPDM DENSIDAD: 0.60 GR/CM ³
26	18	E-450/A0	EPDM DENSIDAD: 0.50 GR/CM ³
32	22	E-361/A0	EPDM DENSIDAD: 0.60 GR/CM ³
35	25	E-359/A0	EPDM DENSIDAD: 0.60 GR/CM ³
38	28	E-362/A0	EPDM DENSIDAD: 0.60 GR/CM ³
42	18	E-360/A0	EPDM DENSIDAD: 0.60 GR/CM ³
45.6	32.7	E-626/A0	EPDM DENSIDAD: 0.40 GR/CM ³
68	60	E-375/A0	EPDM DENSIDAD: 0.40 GR/CM ³

FORMA DE "U" / SPONGE "U" PROFILES

PERFILES SIMÉTRICOS

E-8/A0	E-157/A0	E-282/A0
MATERIAL A CONSULTAR	EPDM DENSIDAD 0.40 GR/CM³	EPDM DENSIDAD 0.55 GR/CM³

E-327/A0	E-357/A0	E-459/A0
EPDM DENSIDAD 0.50 GR/CM³	EPDM DENSIDAD 0.40 GR/CM³	EPDM DENSIDAD 0.50 GR/CM³

E-93/A0	E-97/A0	E-94/A0
MATERIAL A CONSULTAR	EPDM DENSIDAD 0.40 GR/CM³	EPDM DENSIDAD 0.40 GR/CM³

E-111/A0	E-121/A0	E-370/A0
EPDM DENSIDAD 0.40 GR/CM³	EPDM DENSIDAD 0.45 GR/CM	EPDM DENSIDAD 0.40 GR/CM³

E-410/A0	E-335/A0	E-271/A0
EPDM DENSIDAD 0.50 GR/CM³	MATERIAL A CONSULTAR	EPDM DENSIDAD 0.40 GR/CM³

E-371/A0	E-246/A0	E-248/A0
EPDM DENSIDAD 0.40 GR/CM³	EPDM DENSIDAD 0.50 GR/CM³	MATERIAL A CONSULTAR

E-249/A0	E-338/A0	E-206/A0
MATERIAL A CONSULTAR	MATERIAL A CONSULTAR	EPDM DENSIDAD 0.40 GR/CM³

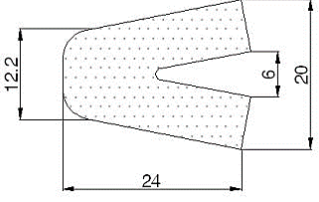
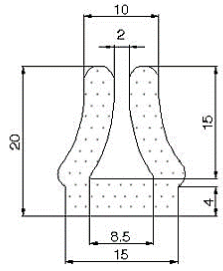
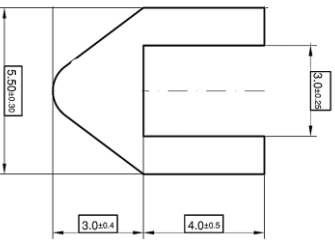
E-263/A0	E-270/A0	E-602/A0
		
<p>EPDM DENSIDAD 0.40 GR/CM³</p>	<p>EPDM DENSIDAD 0.40 GR/CM³</p>	<p>EPDM DENSIDAD 0.50 GR/CM³</p>

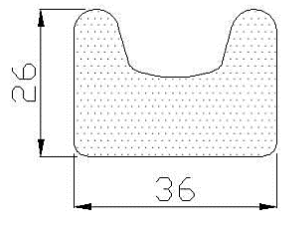
E-223/A0

<p>MATERIAL A CONSULTAR</p>

PERFILES ASIMÉTRICOS

E-328/A0	E-333/A0	E-354/A0
EPDM DENSIDAD 0.50 GR/CM³	EPDM DENSIDAD 0.50 GR/CM³	EPDM DENSIDAD 0.55 GR/CM³

E-412/A0	E-373/A0	E-520/A0
EPDM DENSIDAD 0.50 GR/CM³	EPDM DENSIDAD 0.70 GR/CM³	EPDM DENSIDAD 0.40 GR/CM³

E-31/A0	E-326/A0	E-461/A0
EPDM DENSIDAD 0.45 GR/CM³	EPDM DENSIDAD 0.55 GR/CM³	MATERIAL A CONSULTAR

E-11/A0	E-569/A0	E-240/A0
MATERIAL A CONSULTAR	EPDM DENSIDAD 0.40 GR/CM³	EPDM DENSIDAD 0.50 GR/CM³

E-254/A0	E-171/A0	E-277/A0
EPDM DENSIDAD 0.40 GR/CM³	MATERIAL A CONSULTAR	EPDM DENSIDAD 0.50 GR/CM³

E-289/A0	E-347/A0	E-308/A0
EPDM DENSIDAD 0.45 GR/CM³	EPDM DENSIDAD 0.70 GR/CM³	EPDM DENSIDAD 0.40 GR/CM³

E-536/A0	E-620/A0	E-601/A0
EPDM DENSIDAD 0.50 GR/CM³	EPDM DENSIDAD 0.60 GR/CM³	EPDM DENSIDAD 0.60 GR/CM³

E-605/A0	E-649/A0	E-477/A0
EPDM DENSIDAD 0.55 GR/CM³	EPDM DENSIDAD 0.60 GR/CM³	EPDM DENSIDAD 0.50 GR/CM³

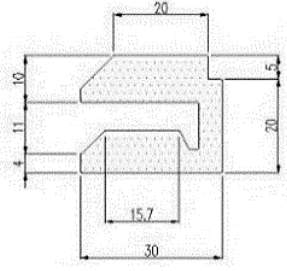
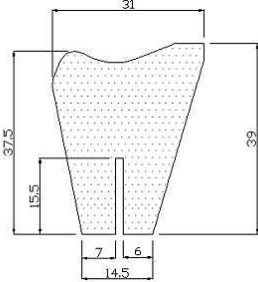
E-537/A0	E-152/A0
	
EPDM DENSIDAD 0.60 GR/CM³	EPDM DENSIDAD 0.40 GR/CM³

PARA **OTRAS**
GEOMETRÍAS DE
ESPONJA ESCRIBIR A

FOR OTHER GEOMETRIES, WRITE TO
COMERCIAL@RIALS.ES

CALLE PRIMAVERA 9, PARQUE
INDUSTRIAL "LAS MONJAS", TORREJÓN
DE ARDOZ, 28850, COMUNIDAD DE
MADRID, ESPAÑA

(Telf) +34 91 677 06 85

(FAX) +34 91 678 11 49

PUEDES SEGUIRNOS EN

 Rials Extrusión Técnica S.L.

MUCHO MÁS EN WWW.RIALS.ES