

CATÁLOGO DE PERFILES DE DEFENSA

RUBBER D-FENDERS PROFILE CATALOG

PERFILES DE PROTECCIÓN Y
DEFENSAS PARA LA INDUSTRIA.
EN MATERIALES EPDM, CR...

71/A0

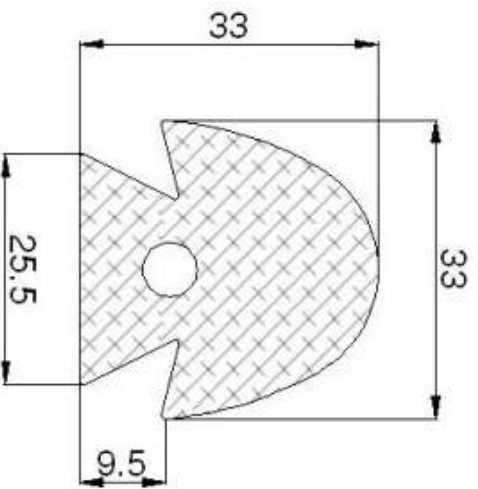

EPDM 60° Sh.A

73/A0

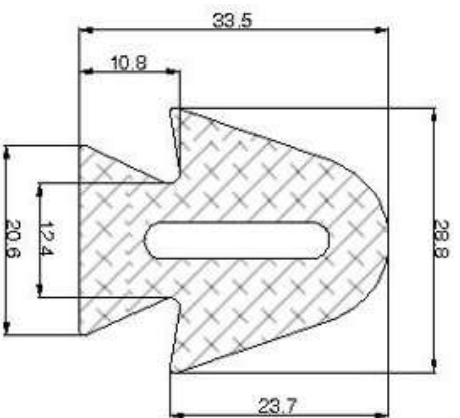

EPDM 60° Sh.A

78/A0

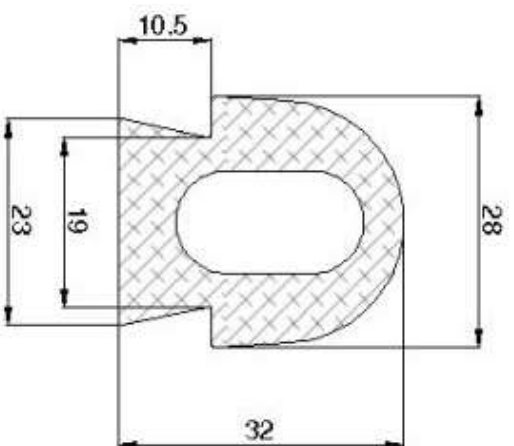

EPDM 60° Sh.A

133/A0

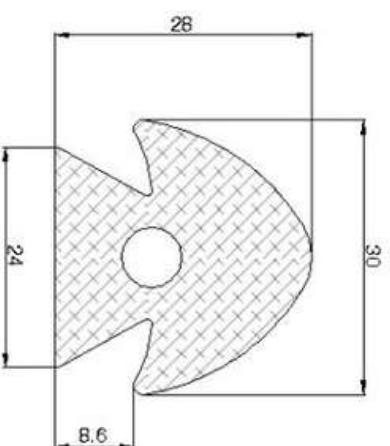

A CONSULTAR

158/A0

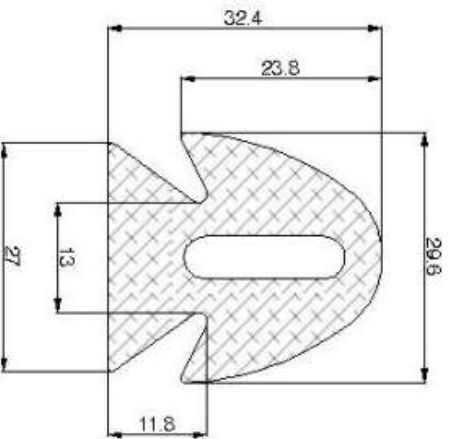

EPDM 60° Sh.A

252/A0

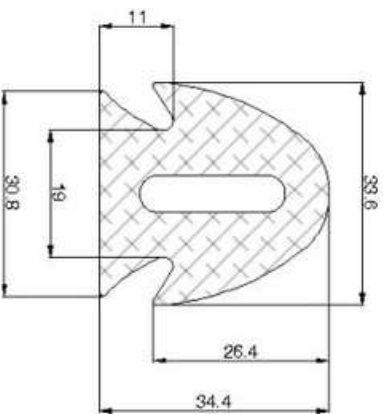

EPDM 60° Sh.A

281/A0

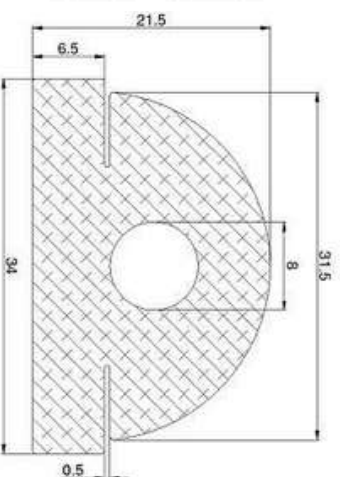

EPDM 60° Sh.A

505/A0

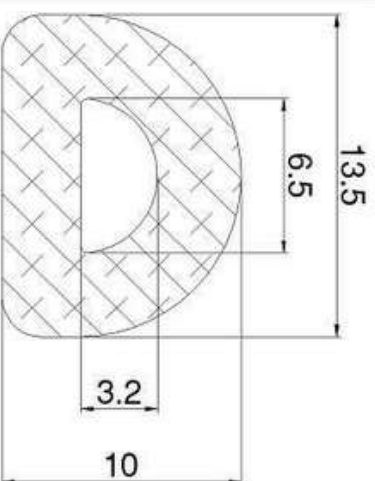

EPDM 60° Sh.A

518/A0

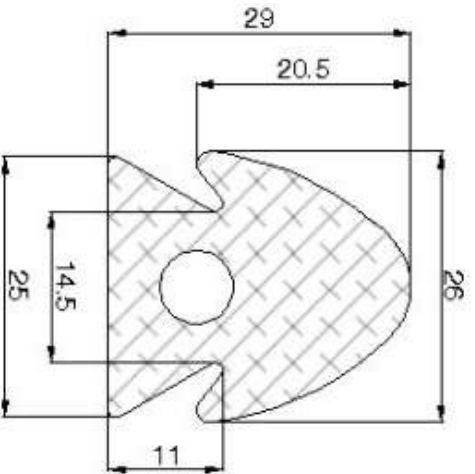

EPDM 60° Sh.A

632/A0

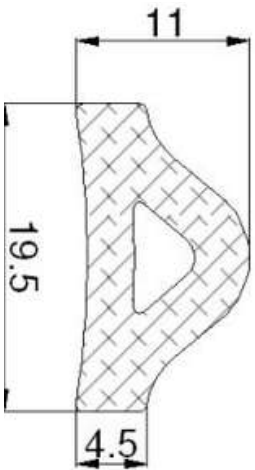

EPDM 60° Sh.A

729/A0

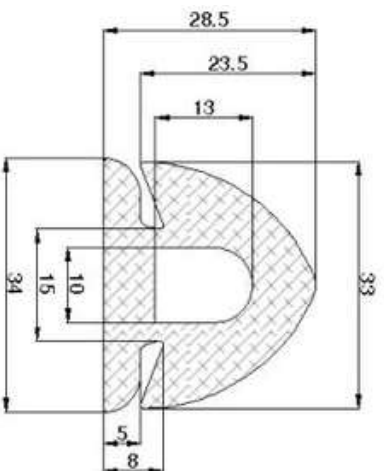

EPDM 60° Sh.A

952/A0

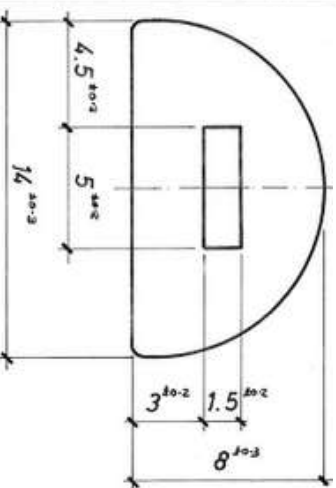

EPDM 60° Sh.A

1029/A0

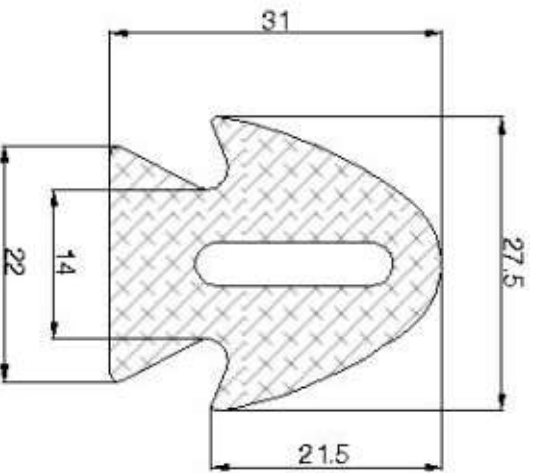

A CONSULTAR

1110/A0

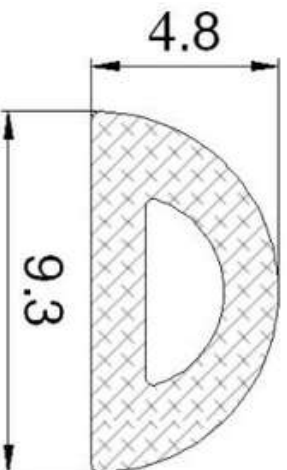

EPDM 60° Sh.A

1279/A0

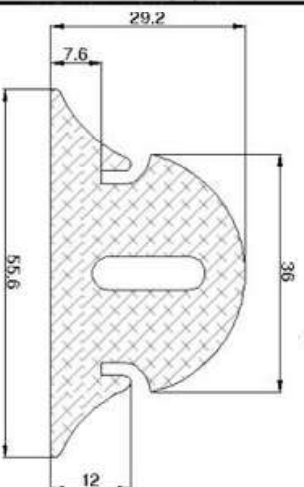

A CONSULTAR

1355/A0

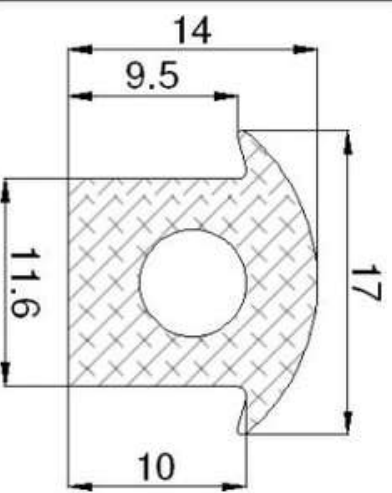

A CONSULTAR

1394/A0

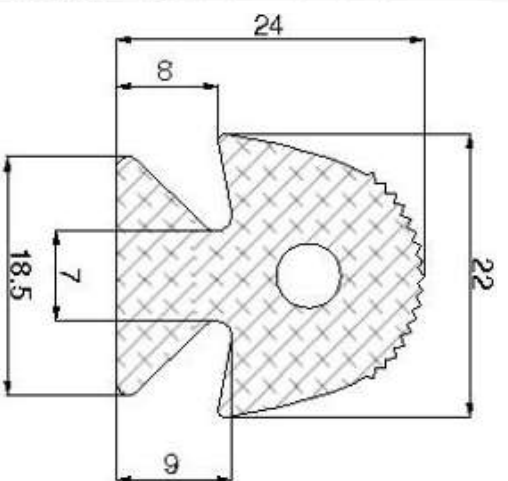

EPDM 60° Sh.A

1511/A0

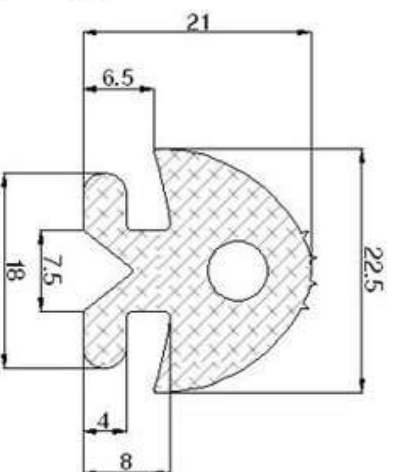

EPDM 60° Sh.A

1562/A0

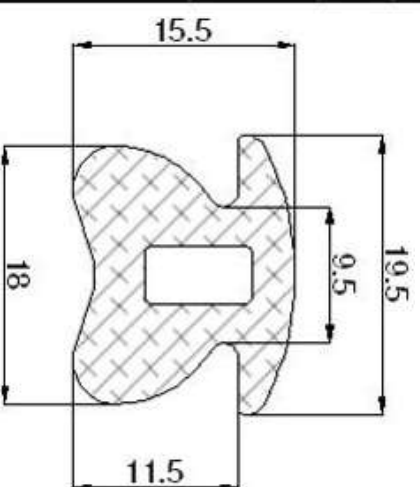

A CONSULTAR

1596/A0

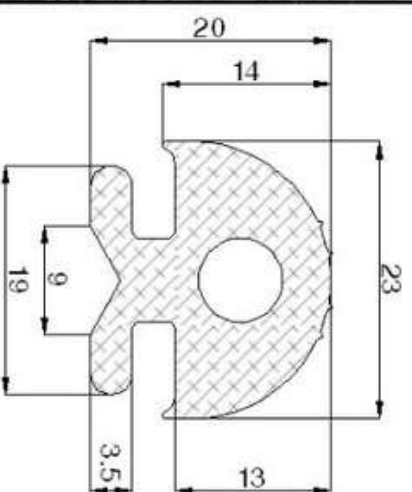

EPDM 60° Sh.A

1619/A0

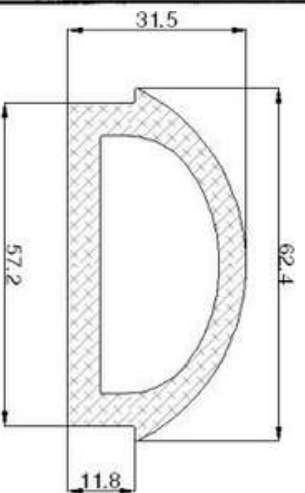

EPDM 60° Sh.A

1764/A0

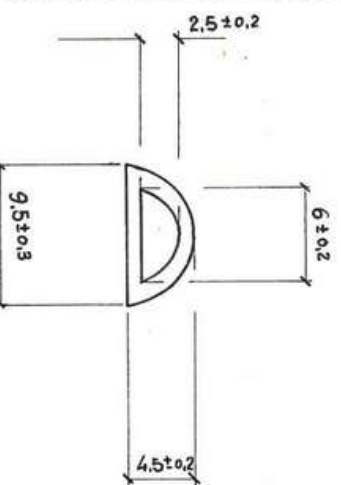

A CONSULTAR

1787/A0

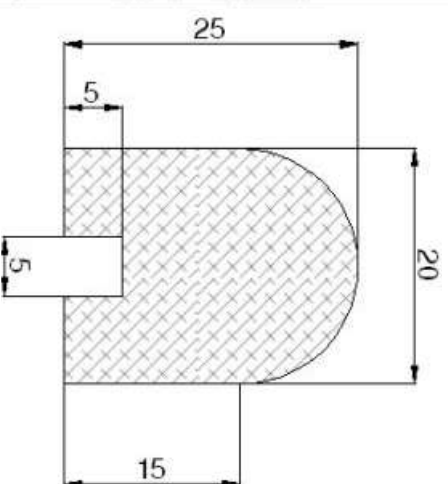

EPDM 60° Sh.A

1875/A0

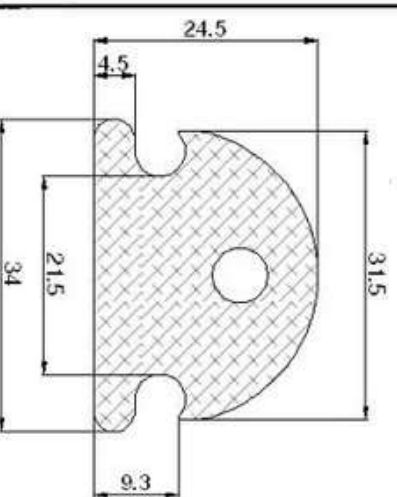

EPDM 70° Sh.A

1981/A0

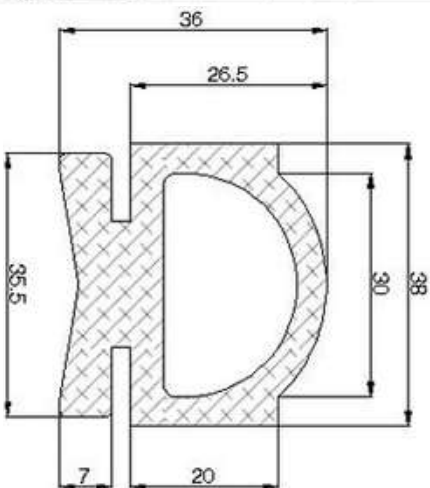

A CONSULTAR

2052/A0

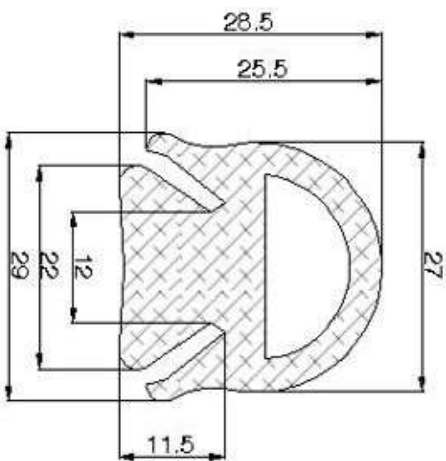

A CONSULTAR

2207/A0

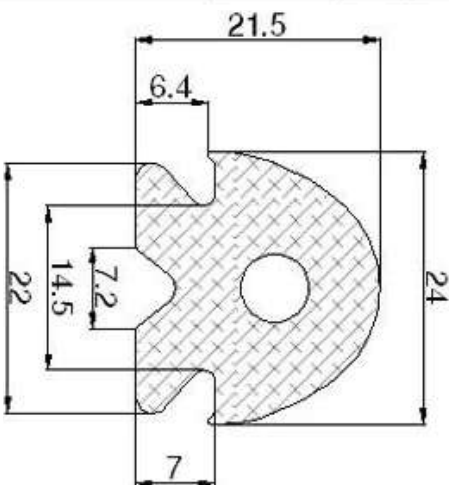

EPDM 60° Sh.A

2243/A0

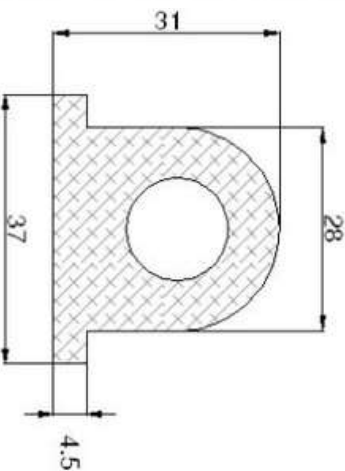

A CONSULTAR

2373/A0

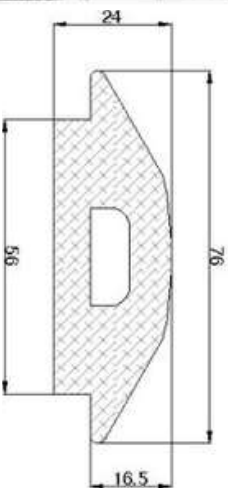

2439/A0

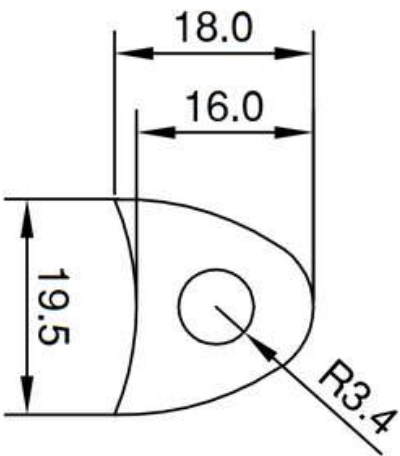

2445/A0

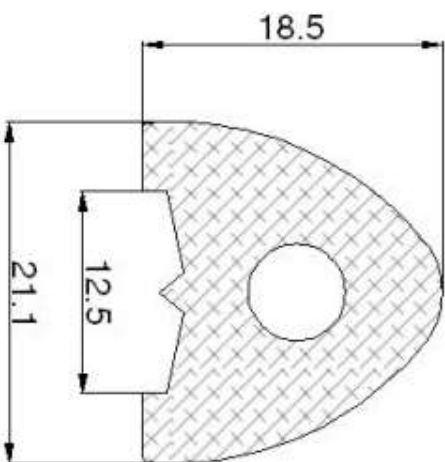

2505/A0

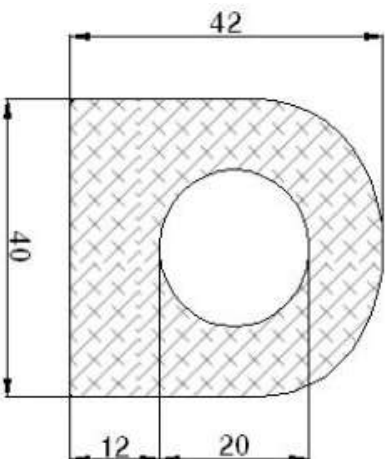

EPDM 60° Sh.A

CR 70° Sh.A

A CONSULTAR

EPDM 60° Sh.A
EPDM 70° Sh.A

2735/A0

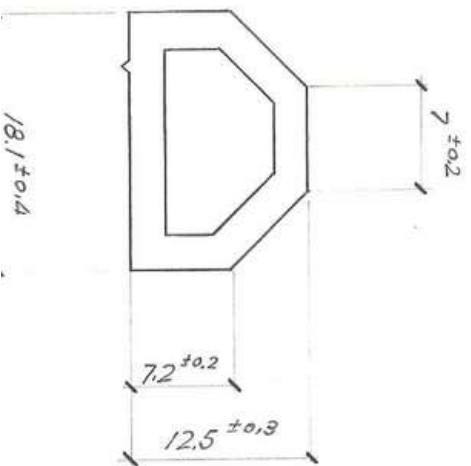

EPDM 60° Sh.A

2878/A0

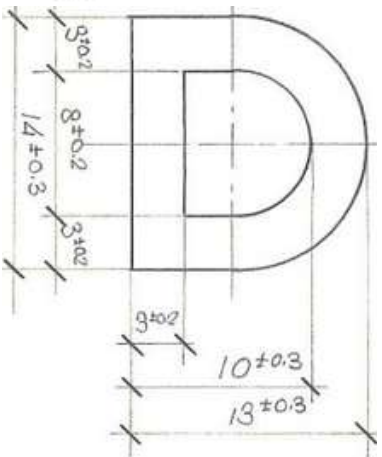

EPDM 60° Sh.A

3422/A0

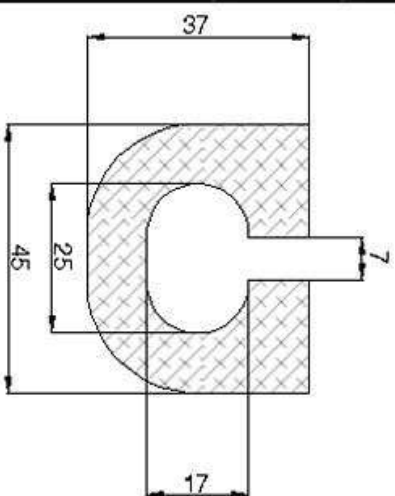

EPDM 60° Sh.A

PÁGINA 5



3525/A0

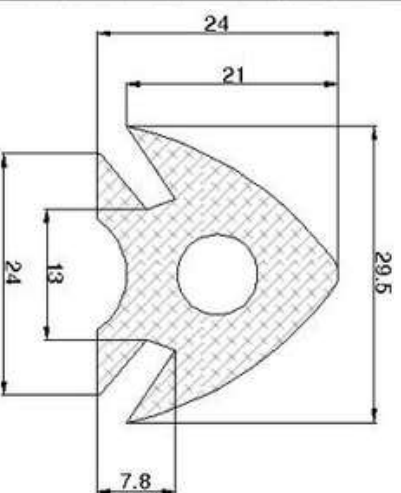

A CONSULTAR

3626/A0

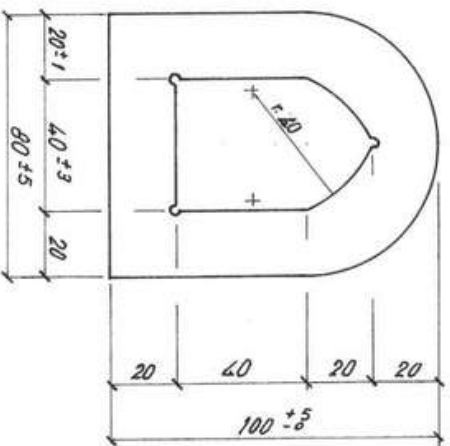

EPDM 70° Sh.A

3644/A0

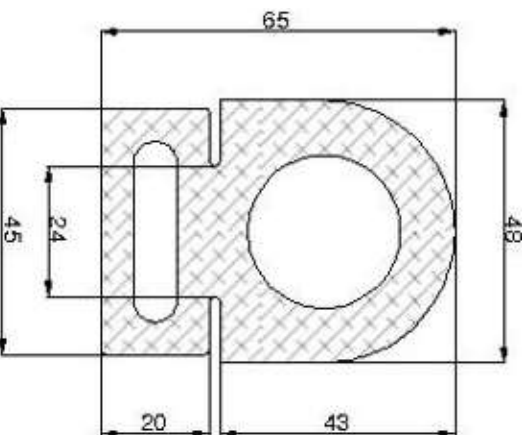

EPDM 60° Sh.A

3721/A0

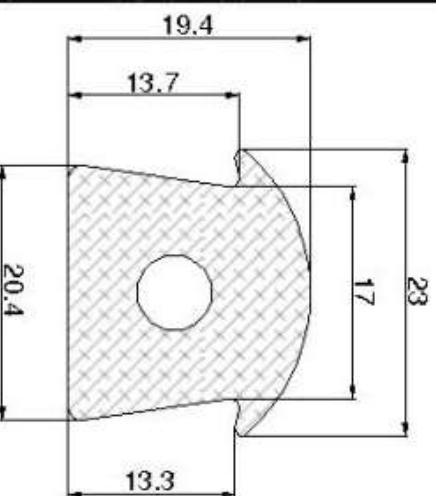

EPDM 60° Sh.A

3764/A0

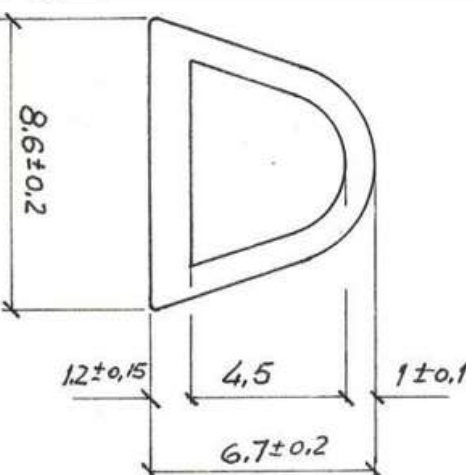

CR 70° Sh.A

3789/A0

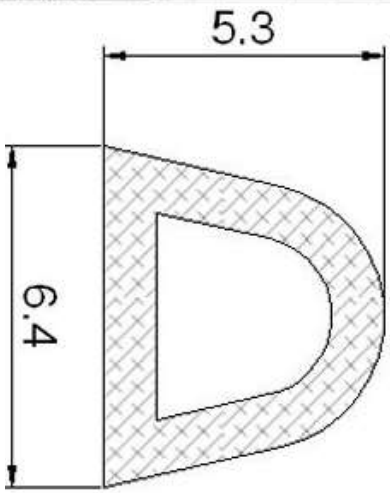

EPDM 70° Sh.A

4434/A0

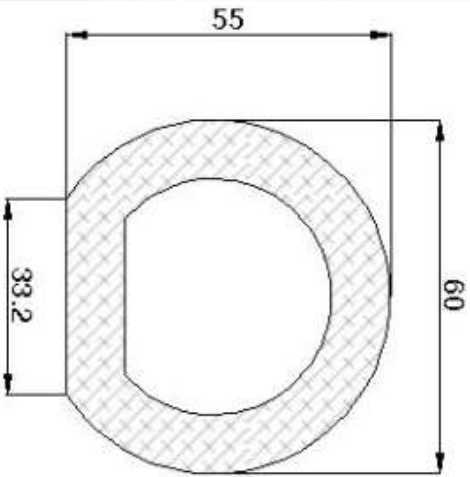

EPDM 60° Sh.A

3982/A0

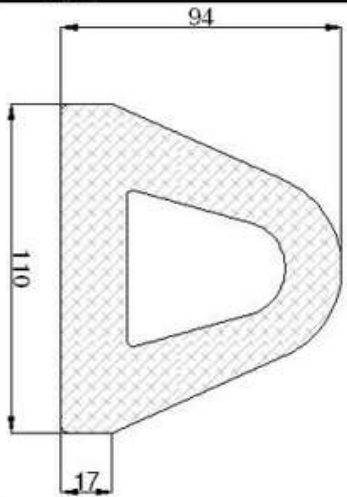

EPDM 50° Sh.A
EPDM 60° Sh.A
EPDM 70° Sh.A

4435/A0

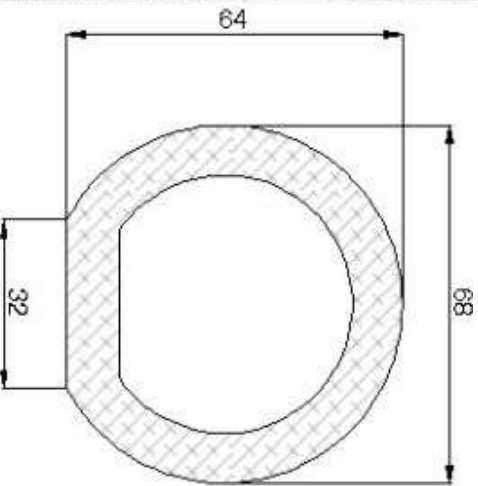

EPDM 60° Sh.A

4123/A0

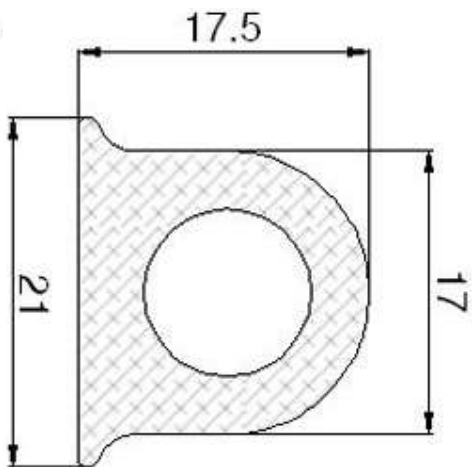

EPDM 60° Sh.A

4684/A0

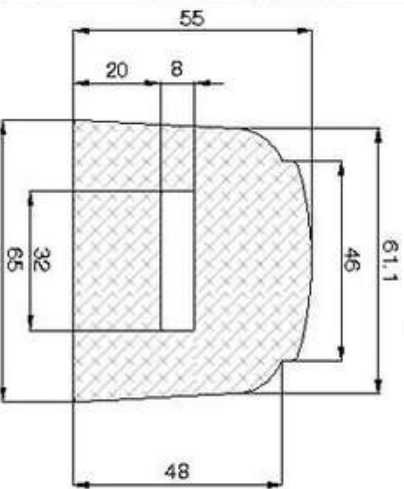

EPDM 60° Sh.A

4328/A0

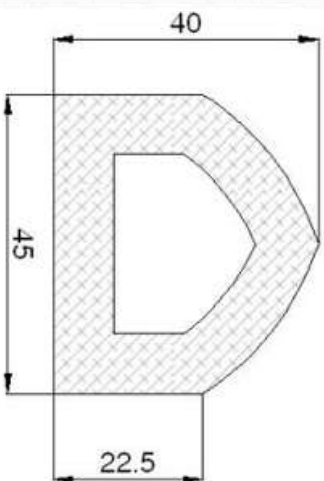

EPDM 60° Sh.A

4821/A0

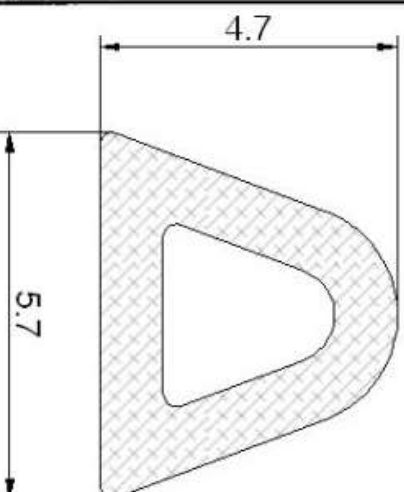

EPDM 70° Sh.A

5873/A0

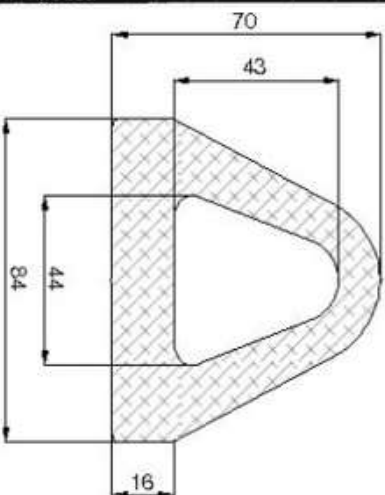

EPDM 70° Sh.A

6361/A0

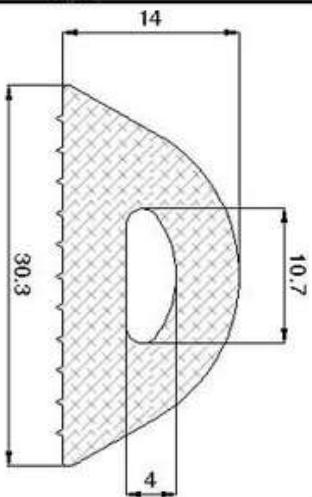

EPDM 70° Sh.A

6403/A0

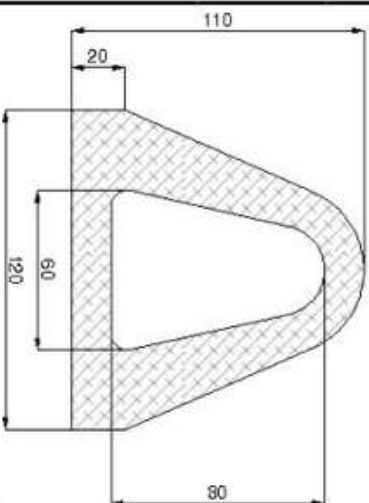

EPDM 60° Sh.A
EPDM 70° Sh.A



6583/A0

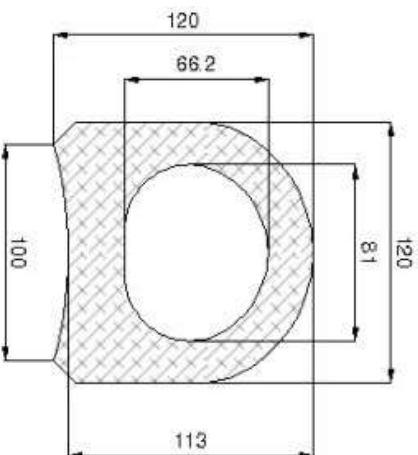

EPDM 60° Sh.A

6723/A0

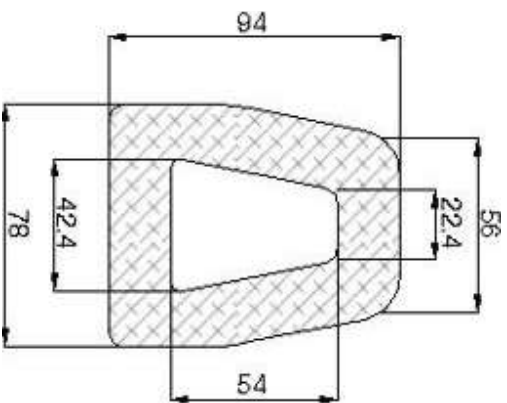

EPDM 60° Sh.A
EPDM 70° Sh.A

6932/A0

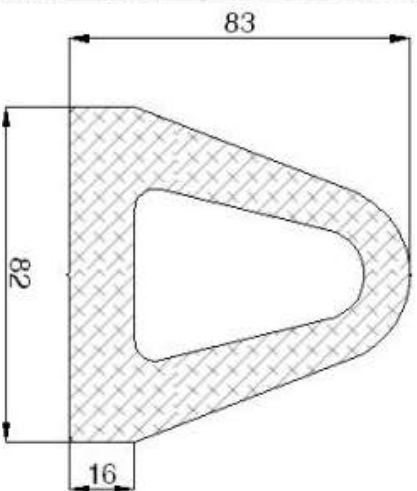

EPDM 60° Sh.A
EPDM 70° Sh.A

6970/A0

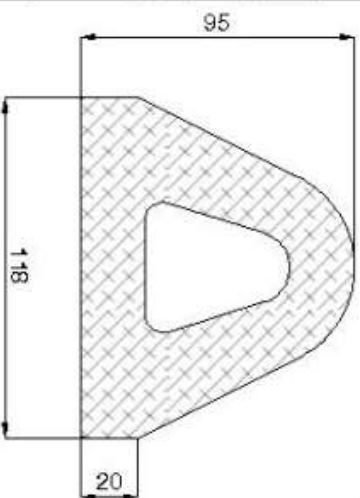

EPDM 60° Sh.A

7075/A0

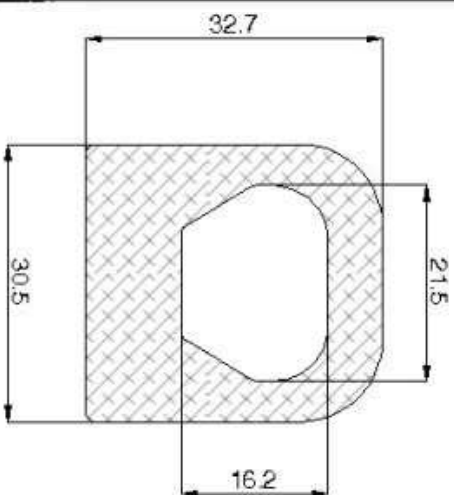

A CONSULTAR

7084/A0

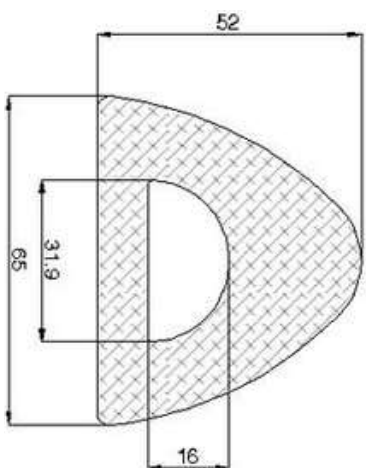

EPDM 80° Sh.A

7085/A0

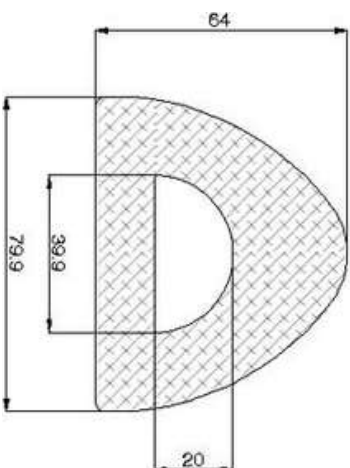

EPDM 80° Sh.A

7103/A0

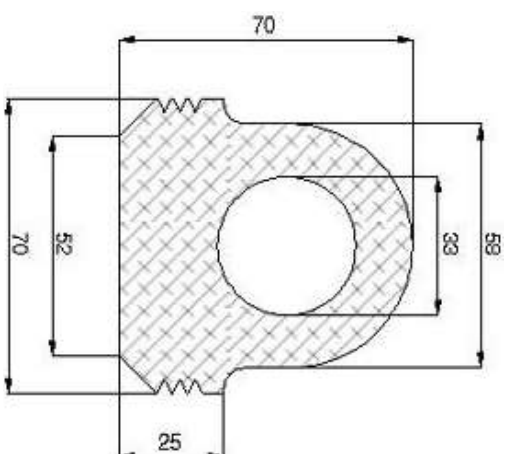

A CONSULTAR

7142/A0

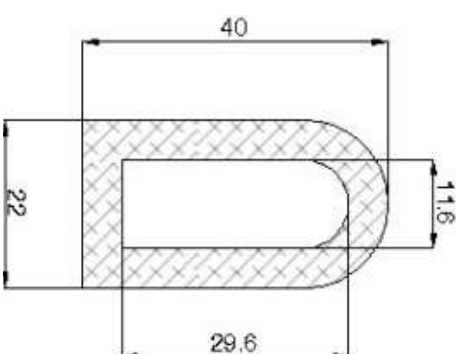

EPDM 60° Sh.A

7143/A0

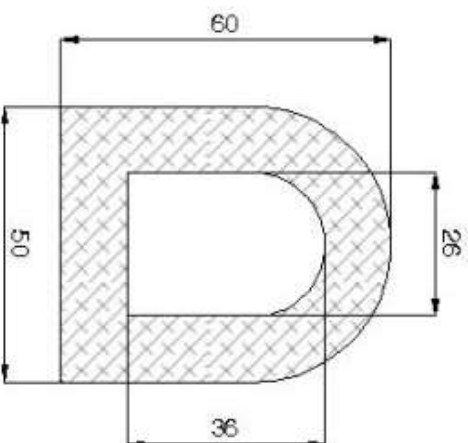

EPDM 60° Sh.A

7171/A0

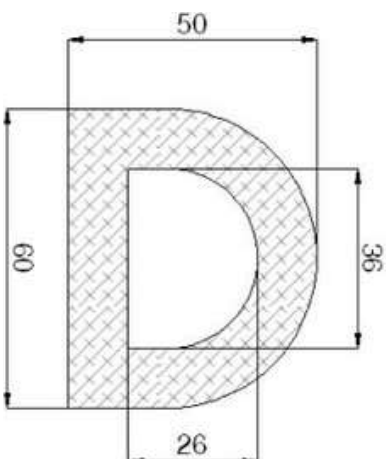

EPDM 60° Sh.A

7172/A0

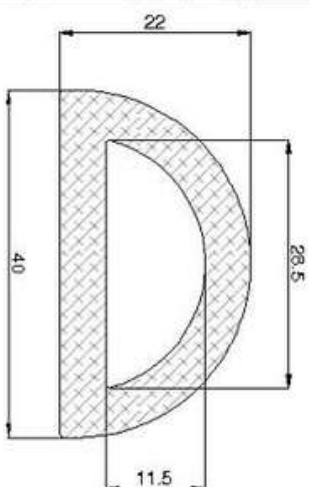

EPDM 60° Sh.A

7207/A0

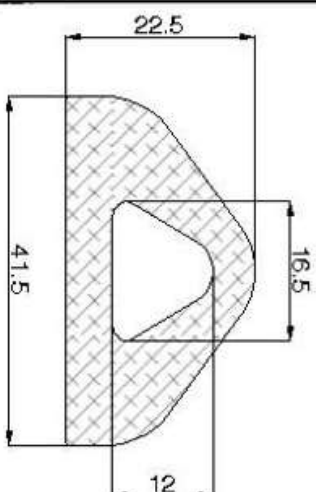

EPDM 60° Sh.A
EPDM 70° Sh.A

7208/A0

EPDM 60° Sh.A
EPDM 70° Sh.A

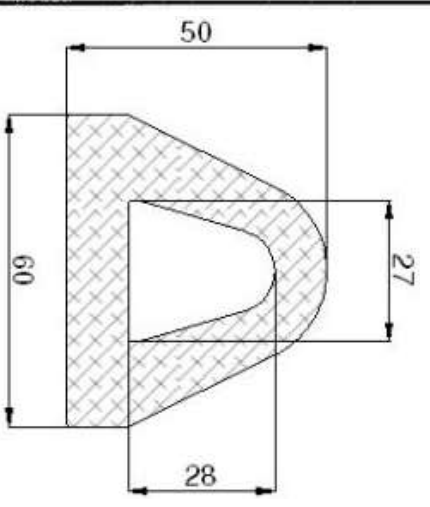

7470/A0

EPDM 60° Sh.A

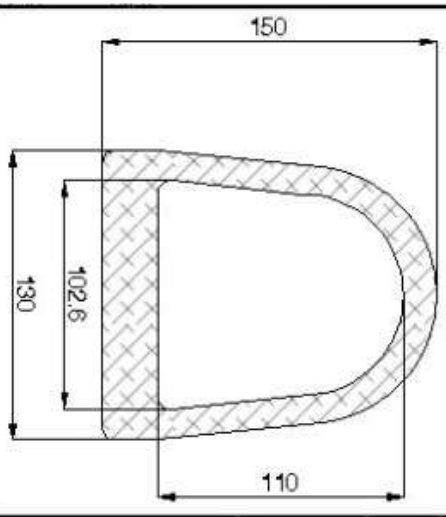

7535/A0

EPDM 60° Sh.A

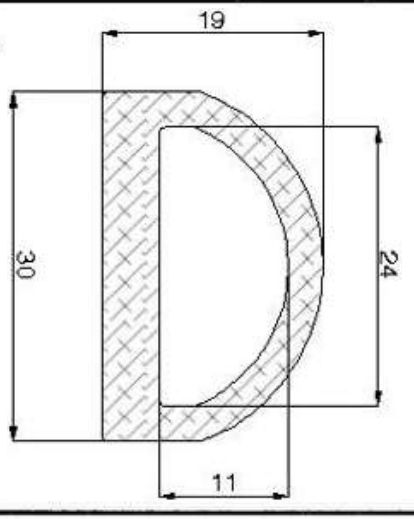

7812/A0

EPDM 60° Sh.A

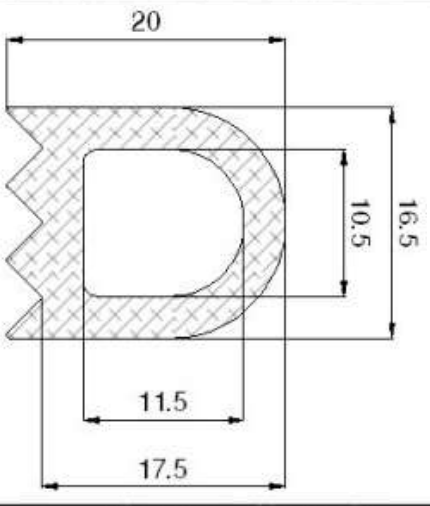

8060/A0

CR 70° Sh.A

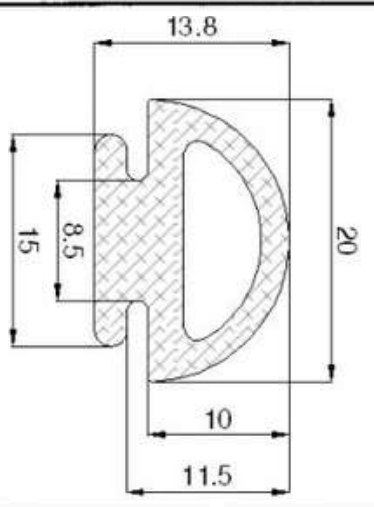

8097/A0

EPDM 60° Sh.A

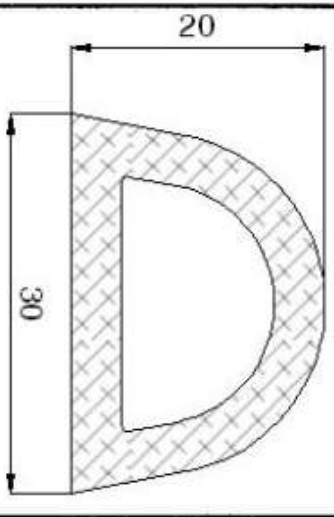

8200/A0

EPDM 50° Sh.A

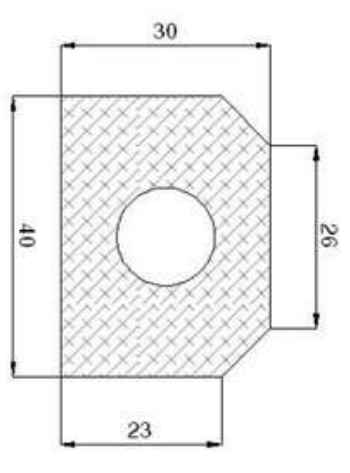

8216/A0

EPDM 50° Sh.A

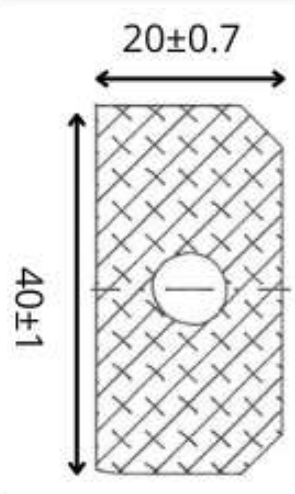

8231/A0

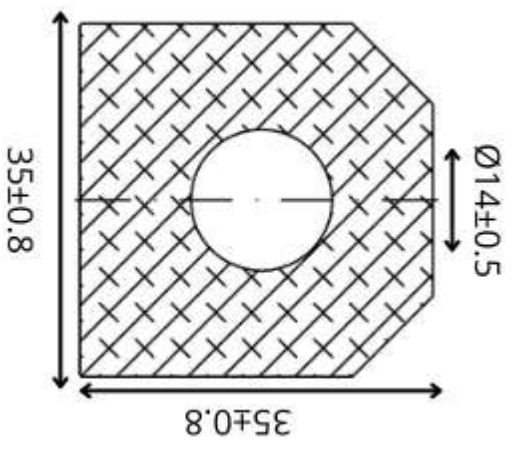

EPDM 50° Sh.A

8233/A0

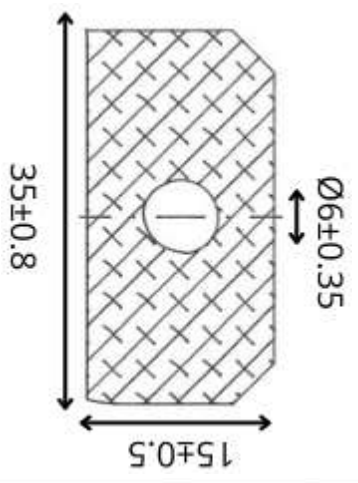

EPDM 50° Sh.A

8236/A0

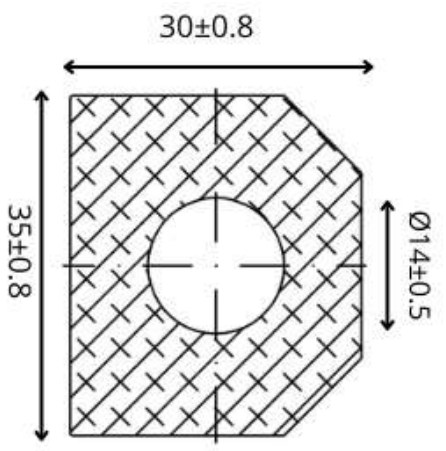

EPDM 50° Sh.A

8268/A0

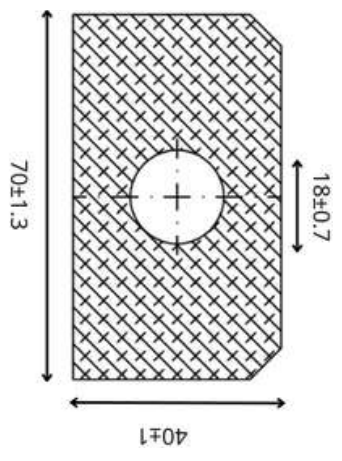

EPDM 50° Sh.A

8332/A0

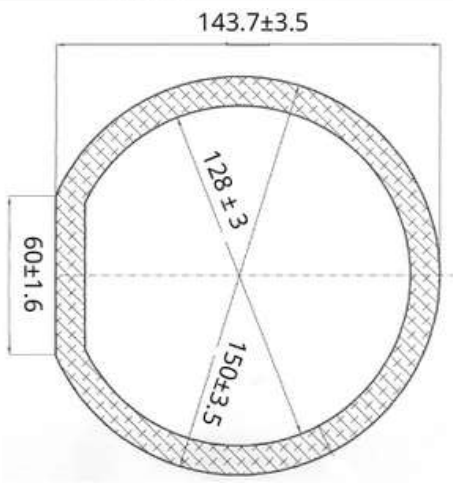

EPDM 60° Sh.A

8359/A0

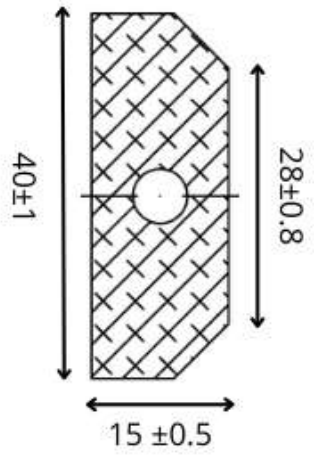

EPDM 50° Sh.A

8360/A0

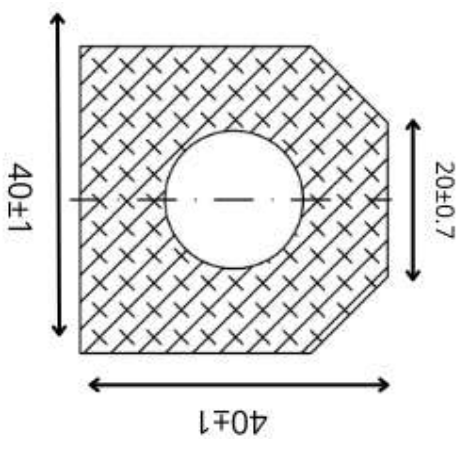

EPDM 50° Sh.A

8440/A0

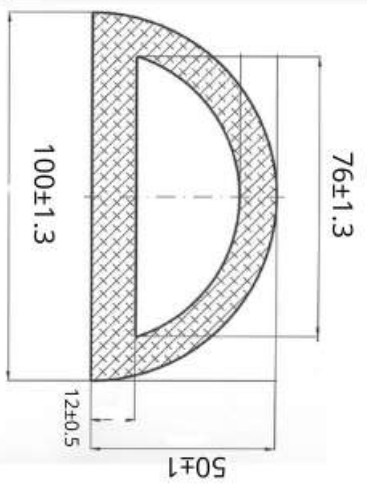

EPDM 60° Sh.A

8441/A0

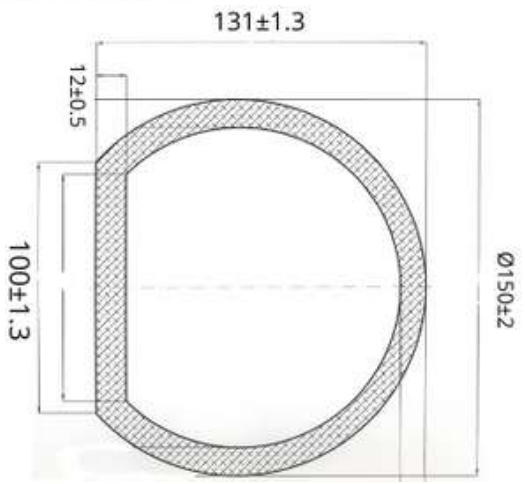

EPDM 60° Sh.A

8475/A0

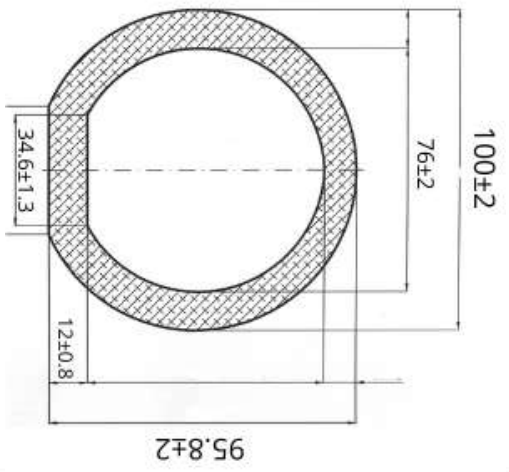

EPDM 60° Sh.A

8804/A0

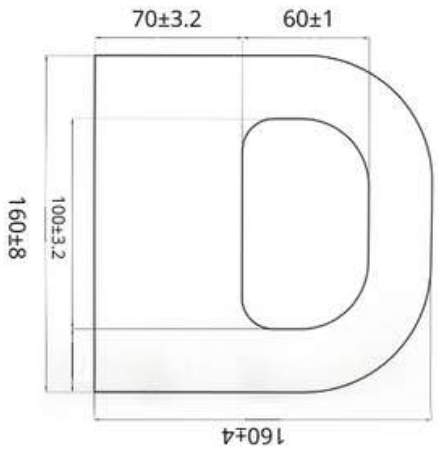

EPDM 60° Sh.A

8906/A0

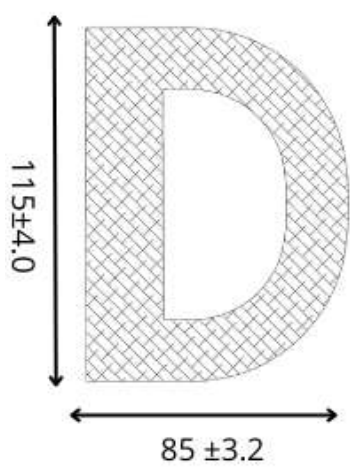

EPDM 50° Sh.A
 EPDM 60° Sh.A

9071/A0

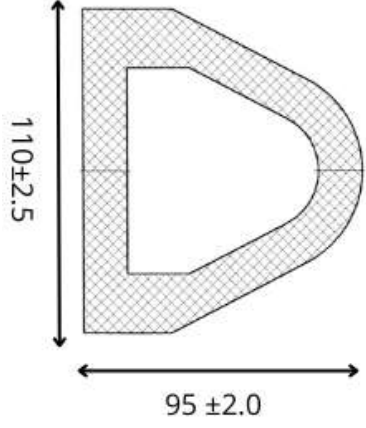

EPDM 70° Sh.A

9073/A0

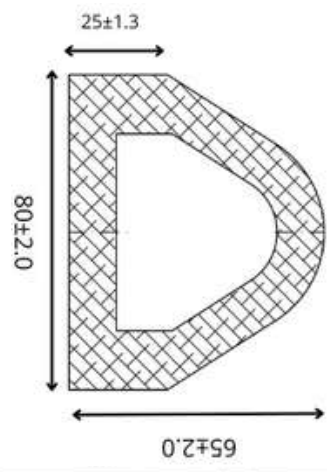

EPDM 70° Sh.A

9169/A0

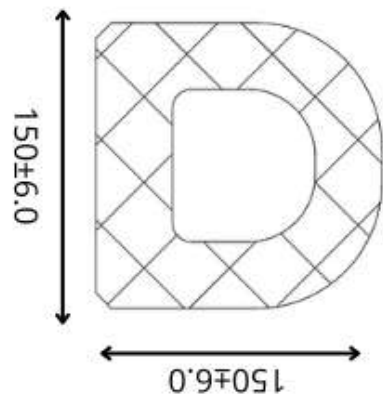

EPDM 60° Sh.A

9179/A0

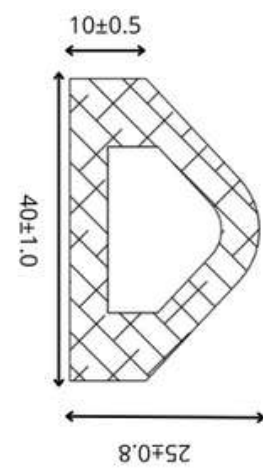

EPDM 70° Sh.A

9182/A0

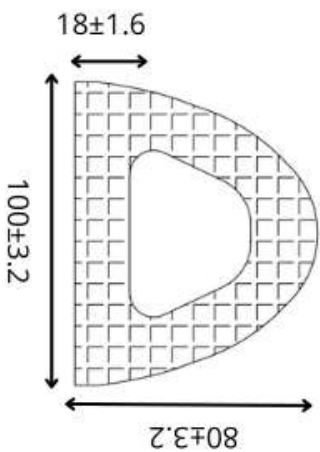

EPDM 70° Sh.A

9183/A0

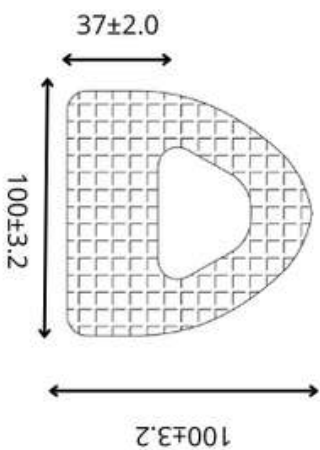

EPDM 60° Sh.A

9273/A0

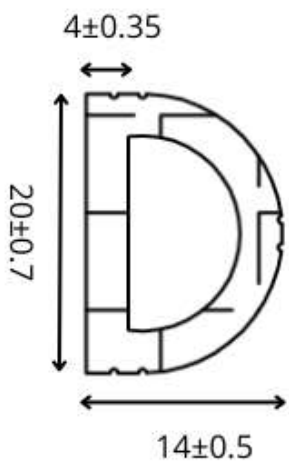

EPDM 60° Sh.A
EPDM 70° Sh.A

9307/A0

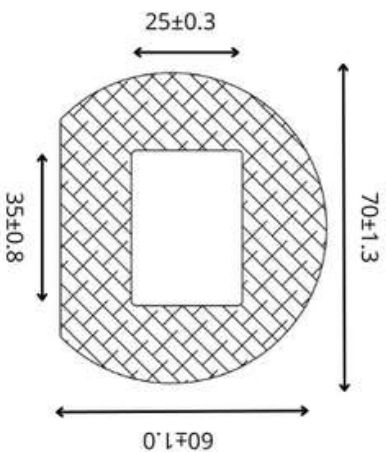

EPDM 60° Sh.A

CONTAMOS CON MÁS GEOMETRÍAS QUE NO
HAN PODIDO SER INCLUIDAS EN EL CATÁLOGO.

**PARA OTRAS
GEOMETRÍAS ESCRIBIR A
FOR OTHER GEOMETRIES, WRITE TO**

COMERCIAL@RIALS.ES

**CALLE PRIMAVERA 9, PARQUE
INDUSTRIAL "LAS MONJAS", TORREJÓN
DE ARDOZ, 28850, COMUNIDAD DE
MADRID, ESPAÑA**

PUEDES SECUIRNOS EN



Rials Extrusión Técnica S.L.

[MUCHO MÁS EN WWW.RIALS.ES](http://WWW.RIALS.ES)

(Telf) +34 91 677 06 85

(FAX) +34 91 678 11 49